

## FPT

700 bar  
Single – Double stage  
0,9/0,45 - 7,5/0,9 l/min oil flow  
From 10 to 60 l capacity

Series  
**FPT**

## Pneumohydraulic and electric pumps

### Maximum versatility and performance



- The FPT model hydraulic pumps are the ideal solution for all industrial applications because of their extreme versatility and customization thanks to multiple configurations.
- Available with three-phase and single-phase electric motor or pneumatic.
- Possibility to install manual, electric or pneumatic, 3 or 4-way valves for single or double-acting cylinders and hydraulic equipment.
- With strong steel tank from 10 to 60 liters.
- Reduced maintenance. Designed to last.
- Wide range of accessories.
- Possibility to design and produce custom hydraulic pumps on request, with dedicated performance and features.

### CUSTOM HYDRAULIC PUMPS ON REQUEST



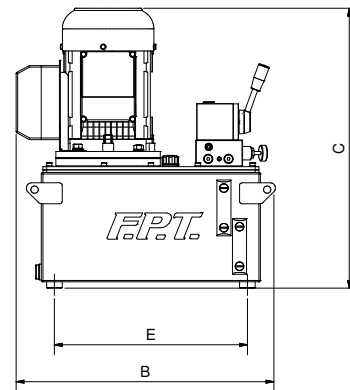
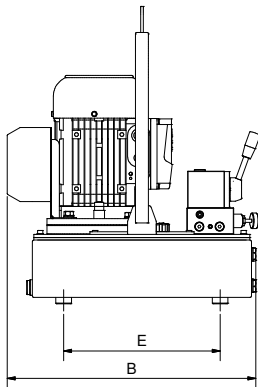
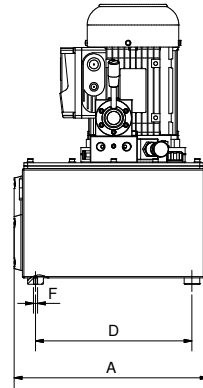
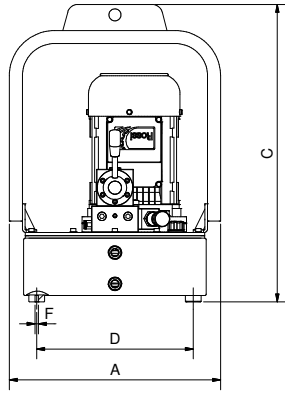

10L

20 - 40 - 60L

MODEL	PRESSURE RATING 1st/2nd STAGE	OIL DISPLACEMENT 1st/2nd STAGE	MOTOR	KW RPM
	bar			
FPT 1 - ME4	100 / 700	0,9 / 0,45	THREE-PHASE 4 POLES	1,1 / 1450
FPT 1 - ME41		0,9 / 0,45	SINGLE-PHASE 4 POLES	1,1 / 1450
FPT 1 - ME2		1,8 / 0,9	THREE-PHASE 2 POLES	2,2 / 2850
FPT 1 - ME21		1,8 / 0,9	SINGLE PHASE 2 POLES	2,2 / 2850
FPT 1 - MA		1,8 / 0,9	PNEUMATIC	2,6 / 3000
FPT 2 - ME4		700	0,9	THREE-PHASE 4 POLES
FPT 2 - ME41	0,9		SINGLE-PHASE 4 POLES	1,1 / 1450
FPT 2 - ME2	1,8		THREE-PHASE 2 POLES	2,2 / 2850
FPT 2 - ME21	1,8		SINGLE PHASE 2 POLES	2,2 / 2850
FPT 2 - MA	1,8		PNEUMATIC	2,6 / 3000
FPT 5 - ME4	70 / 700		2,5 / 0,9	THREE-PHASE 4 POLES
FPT 5 - ME41		2,5 / 0,9	SINGLE-PHASE 4 POLES	1,1 / 1450
FPT 5 - ME2		4,5 / 1,8	THREE-PHASE 2 POLES	2,2 / 2850
FPT 5 - ME21		4,5 / 1,8	SINGLE PHASE 2 POLES	2,2 / 2850
FPT 5 - MA		4,5 / 1,8	PNEUMATIC	2,6 / 3000
FPT 9 - ME4		70 / 700	3,5 / 0,45	THREE-PHASE 4 POLES
FPT 9 - ME41	3,5 / 0,45		SINGLE-PHASE 4 POLES	1,1 / 1450
FPT 9 - ME2	7,5 / 0,9		THREE-PHASE 2 POLES	2,2 / 2850
FPT 9 - ME21	7,5 / 0,9		SINGLE PHASE 2 POLES	2,2 / 2850
FPT 9 - MA	7,5 / 0,9		PNEUMATIC	2,6 / 3000

MOTOR	OILTANK CAPACITY	DIMENSIONS in mm						WEIGHT kg
		A	B	C	D	E	F	
Electric ME	10	405	480	580	300	300	M8	36
	20	380	500	540	300	370	M8	49
	40	610	490	540	500	370	M8	69
	60	860	490	540	750	370	M8	91
Pneumatic MA	10	405	450	580	300	300	M8	33
	20	380	480	440	300	370	M8	46
	40	610	450	440	500	370	M8	56
	60	860	490	440	750	370	M8	87

Pneumatic and Electric pump's dimensions – NO CAGE

MOTOR	OILTANK CAPACITY	DIMENSIONS in mm		
		A	B	C
Electric and Pneumatic ME - MA	10	470	570	570
	20	470	620	620
	40	750	540	620
	60	1000	540	620

Pneumatic and Electric pump's dimensions – WITH CAGE

# Valves for hydraulic pumps

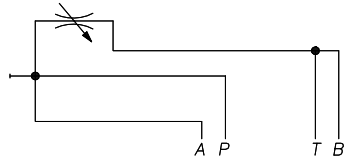
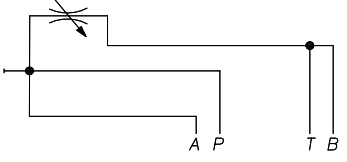
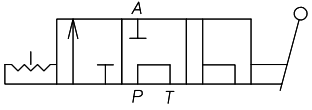
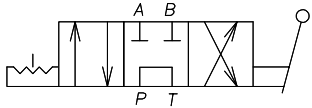
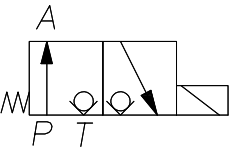
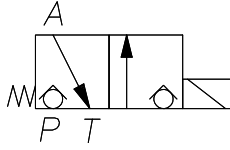
MODEL	DRIVE	HYDRAULIC DIAGRAM	DESCRIPTION
PT	Manual		P-T Block (with pressure relief knob)
VM32	Manual		Manual valve for single acting cylinders (bypass knob) 3 way / 2 position
VM33	Manual		Manual valve for single acting cylinders 3 way / 3 position
VM43/VM43D	Manual		Manual valve for oil return cylinders 4 way / 3 position
VE32	Electric		Solenoid valve for single acting cylinders 3 way / 2 position
VE32A	Electric		Solenoid valve for single acting cylinders 3 way / 2 position for accessories

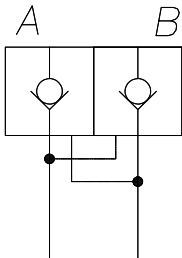
MODEL	DESCRIPTION	HYDRAULIC DIAGRAM	ASSEMBLE ON	DESCRIPTION
RP	Pilot operated check valve		VE43/VE43D – VM43/VM43D – VP43/VP43D – VM33	Dual Pilot Operated Check Valve consists of two checkers (both on A and on B) which ensure perfect load holding. Example: With a non pilot operated manual valve when switching from position A to the central hold position, a small pressure drop occurs due to the geometry of the valve: it is a very small leakage but in some cases it is not acceptable. The check valve helps to overcome this problem. It is required in split-flow pumps when no overcenter is equipped.

MODEL	DRIVE	HYDRAULIC DIAGRAM	DESCRIPTION
VE33	Electric		Solenoid valve for single acting cylinders 3 way / 3 position
VE43/VE43D	Electric		Solenoid valve for oil return cylinders 4 way / 3 position
VP32	Pneumatic		Pneumatic valve for single acting cylinders 3 way / 2 position
VP32A	Pneumatic		Pneumatic valve for single acting cylinders 3 way / 2 position for tools
VP33	Pneumatic		Pneumatic valve for single acting cylinders 3 way / 3 position
VP43/VP43D	Pneumatic		Pneumatic valve for oil return cylinders 4 way / 3 position











MODEL	DESCRIPTION	HYDRAULIC DIAGRAM	ASSEMBLE ON	DESCRIPTION
OC	Over-center valve		VE43/VE43D – VM43/VM43D – VP43/VP43D	The over-center valve (or counter-balance) has the purpose of controlling the movement of a hydraulic cylinder subject to negative loads. This valve can only be mounted on double acting or oil return cylinders. Without this valve, the return of the cylinder (during the descent phase) would not be controlled, seriously endangering the operator and the hydraulic system integrity. The valve is pre-calibrated at factory settings and the operator must not make any type of adjustment. The most economical alternative to the over center valve is a unidirectional flow regulator (RFUA). In this case the operator must completely close it before making the lifting and then gradually open it during the descent phase, varying the opening of the valve until the ideal speed is reached. It is clear that this last system is certainly cheaper but it puts the operator at risk due to possible mistakes. Moreover, in combination with the split-flow pump, the over-center valve provides a very high precision even during the return phase.

Accessories  
**FPT**

## Accessories for FPT series hydraulic pumps

The FPT series hydraulic pumps are the ideal solution for all industrial applications because of their maximum versatility and customization thanks to the multiple configurations and the many standard accessories with which they can be equipped.

PICTURE	CODE	NAME	DESCRIPTION
	DLOG	Data-logger	Device capable of recording time / pressure values for subsequent analysis. Data that can be imported into Excel via free FPT software.
	F	Oil filter on return	Recommended for harsh environments: it is important because it increases the life of hydraulic components.
	CP	Foot remote control	To switch on / off the motor and control the valve remotely, 5 meters long electric cable, foot control.
	CD	Remote control	To switch on / off the motor and control the valve remotely, 5 meters long electric cable.
	CDP	Pneumatic remote control	To switch on / off the motor and control the valve remotely, 5 meters long electric cable.
	RF	Unidirectional flow control valve	This valve allows the free flow of oil in one direction and intercepts it in the opposite direction when completely closed. When opened the flow is free in both directions.
	SC	Heat exchanger	This accessory reduces the heating of the oil, particularly suitable for heavy applications
	2U	2 outputs manifold	Manifold to use two cylinders, with integrated needle valves to control the flow of each line

PICTURE	CODE	NAME	DESCRIPTION
	4U	4 outputs manifold	Manifold to use four cylinders, with integrated needle valves to control the flow of each branch.
	G	Cage	Protection frame with wheels to facilitate the transport of the pump and protect it from accidental impacts.
	GR	Cage with wheels	Protection frame to facilitate the transport of the pump and protect it from accidental impacts.
	M100	Pressure gauge	Pressure gauge 0/1000 bar – Ø 100 mm – thread ½" GAS
	S0	No oil	Pump supplied with no oil
	C1	Quick coupler	No.1 Female coupler mod.GR6F – 3/8" NPT
	C2	Quick couplers	No.2 female couplers mod.GR6F – 3/8" NPT
	C4	Quick couplers	No.4 female couplers mod.GR6F – 3/8" NPT
	C8	Quick couplers	No.8 female couplers mod.GR6F – 3/8" NPT
	FRL	FR+L group	Compact group consisting of a filter to retain impurities from the pneumatic circuit, a regulator to allow adjustment of the pressurized air supply, lubricator to make the hydraulic pump work properly.