



MT PORTABLE MACHINES

BRING THE SOLUTION TO YOU...

Manual Flange Facer -FI14M



- | *Manually Operated*
- | *Smooth & ASME B-16.5 standards Finish*
- | *Sturdy Storage*



The *Manual Flange Facing Machine F114M* is rugged, compact and ideal for quickly reconditioning rusty, scarred or worn flange gasket seats to like-new condition in minutes. This easy to operate flange facing tool is perfect for re-facing raised-face and flat-faced flanges on site or in a fabrication/repair shop. The F114M Flange Facer has a clamping range from 1.07" to 10.63" (27.2-270mm) and can machine flanges with a reach up to 14" (355.6mm) O.D. The MT proprietary clamping system is simple to configure and designed for fast set up with accurate alignment. Cutting bits are double sided, long-lasting, and specially formed to cut through a wide variety of material including carbon steel, stainless steel, alloyed steel, aluminum and cast iron. Each tool kit comes ready to use in a sturdy carrying case that keeps everything conveniently organized and readily accessible.

KEY FEATURES

- ⊙ Manually operated, no electric, hydraulic, or air lines necessary
- ⊙ Smooth swing operation produces perfectly precise phonographic finish
- ⊙ Accurately mounts to the flange I.D. in seconds
- ⊙ Feeds available for both smooth and stock finish in accordance with ASME B-16.5 standards
- ⊙ Made of high strength precision machined materials
- ⊙ Sturdy storage/transport case for managing all components
- ⊙ Strong hardware that makes setup fast
- ⊙ Kit comes up ready to use

SPECIFICATION

F114M Manual Flange Facing Machine Specification			
No	Description	Data	
1	Facing Diameter Range	27.2-355.6mm (1.07"-14")	
2	Clamping Diameter Range	27.2-270mm (1.07"-10.63")	
3	Swing Diameter Range	495-582mm (19.5"-22.9")	
4	Tool Post Travel	40mm (1.57")	
5	Power	Manual	
6	Facing Rate	Fine Finish	0.125mm/rev (0.005"/rev)
		ASME B16.5	0.5mm/rev (0.02"/rev)
7	Weight (Machine Only)	9.0Kg	
8	Shipping Weight	29.0 Kg	
9	Crate dimensions (L×W×H)	Plastic box, 680×510×250 mm	

DIMENSIONS

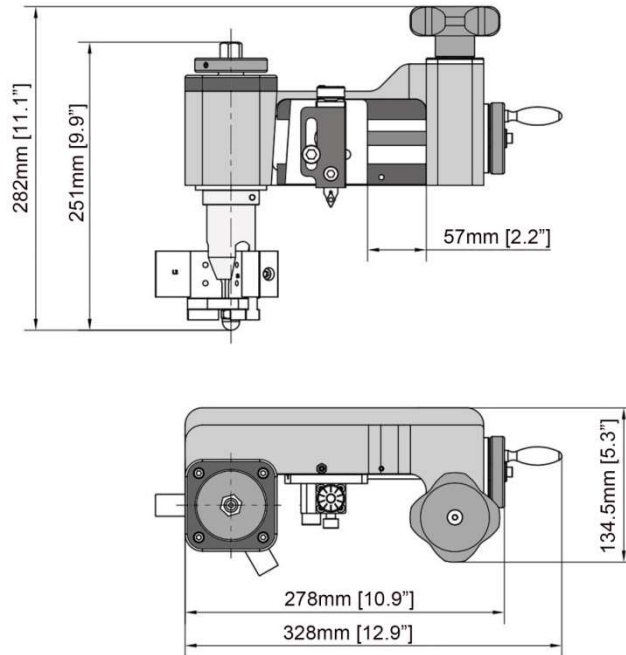

CONFIGURATIONS

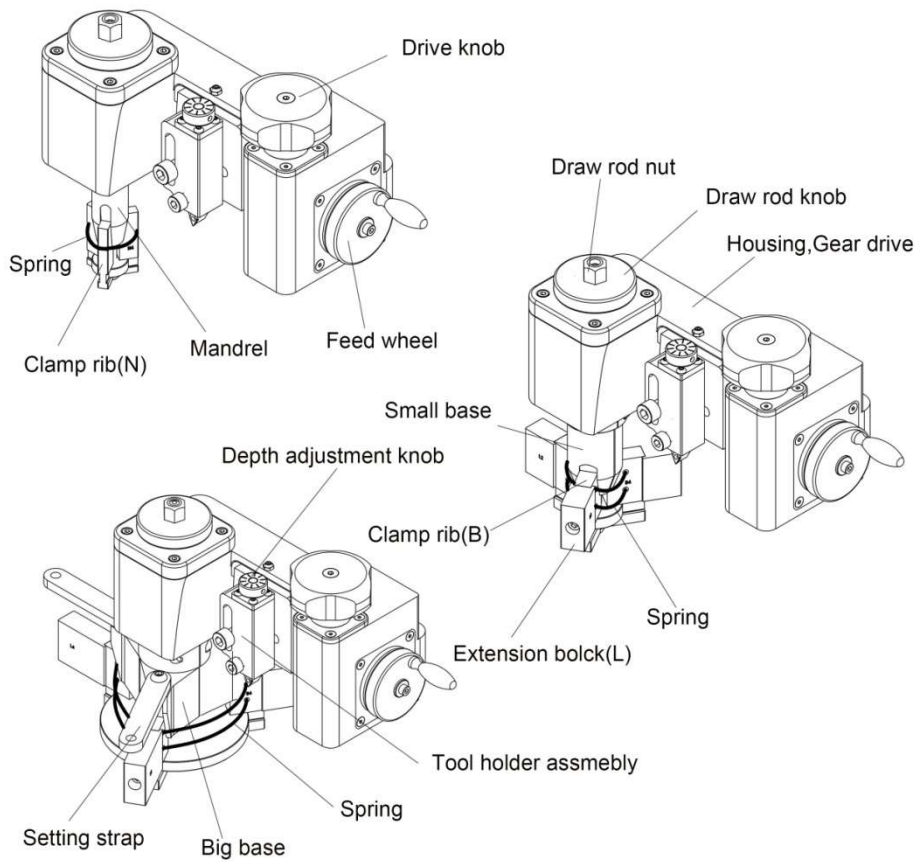

PACKING LIST

Machine Comprising		
No	Description	Qty
1	Housing, Gear drive, Feed assembly	1
2	ASME B16.5 Feed screw & nut	1
3	Toolpost Assembly (Straight toolholder contained)	1
4	90 Tool holder (Left)	1
5	90 Tool holder (Right)	1
6	Draw rod for spindle	1
7	Draw rod for small base	1
8	Draw rod for large base	1
9	Small base	1
10	Large base	1
11	Clamp ribs (N1, N2, N3, N4)	12
12	Clamp ribs (B1, B2, B3, B4)	12
13	Extension block (L1, L2, L3, L4)	12
14	115mm Long, Spring	6
15	300mm Long, Spring	6

Tool Kit Comprising		
No	Description	Qty
1	Metric Hexagon Key Set 1.5-10mm	1
2	17mm Combination Spanner	1
3	T8 Trox Screwdriver	1
4	Plastic hammer	1
5	Socket head screw for Extension block L1 (M6×12)	3
6	Socket head screw for Extension block L2 (M6×25)	3
7	Socket head screw for Extension block L3 (M6×35)	3
8	Socket head screw for Extension block L4 (M6×45)	3
9	Spare screws	1
10	Inserts	10
11	Dial Gauge & Magnetic base	1
12	Clamp chart	1
13	Operation manual	1



APPLICATIONS



Jichuang Machinery Manufacturing Wuxi Co.,Ltd

Add: No.380-4 East Jincheng Road, National Hi-Tech Zone, Wuxi, China

Tel: 0510-88278255 · **Fax:** 0510-88234545 · **E-mail:** info@mtportable.com · **Web:** www.mtportable.com