

F.P.T. TOOLS AND SYSTEMS

Production of custom hydraulic equipment

F.P.T. produces a wide range of standard tools and custom versions to meet customer requirements. This includes hydraulic presses, hydraulic pullers, flange spreaders, wedges, lifting systems for bus maintenance, testing equipment and numerous systems and tools for maintenance and lifting.



INDEX TOOLS AND SYSTEMS

	Series		
Nut splitters	TB		126
Hot Bolt & Industrial Clamp	HBRC		127
Bottle jacks	CB-CBT		128
Hydraulic presses	PR		129

PAGE



Series **TB** **Nut splitters**



- Used when nuts are difficult to remove due to rust or wear.
- Equipped with fixed and mobile blades to cut the nut in a single operation: the blades can be sharpened or replaced.
- Used in the petrochemical, railway and nautical sectors.

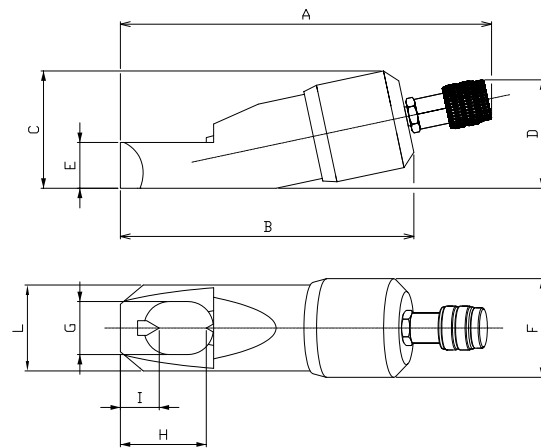

SAFETY INSTRUCTIONS

- Can be used on hexagonal nuts with hardness under 44 HRC
- During the cutting phase, position the blade to the centre of the surface to cut
- Avoid touching the washer if present

SCREW DIAMETER	HEX NUT DIAMETER	MODEL	FORCE in ton	DIMENSIONS in mm										WEIGHT kg	SPARE BLADE MODEL	
				A	B	C	D	E	F	G	H	I	L		FIXED BLADE	MOBILE BLADE
M8 - M12	13 - 19	TB 13/19	5,5	203	133	48	58	19	43	26	41	21	40	1,2	CF-13/19	CM-13/19
M12 - M16	19 - 24	TB 19/24	11	233	163	65	68	25	58	34	47	22	55	2,3	CF-19/24	CM-19/24
M16 - M22	24 - 32	TB 24/32	16,5	260	190	75	74	30	69	41	57	24	63	3,2	CF-24/32	CM-24/32
M22 - M27	32 - 41	TB 32/41	21,8	297	230	90	80	35	84	55	77	35	78	5,1	CF-32/41	CM-32/41
M27 - M33	41 - 50	TB 41/50	35	347	280	112	93	42	103	68	89	38	98	10,4	CF-41/50	CM-41/50
M33 - M39	50 - 60	TB 50/60	49,5	395	330	136	105	52	124	82	103	42	118	17,5	CF-50/60	CM-50/60
M39 - M48	60-75	TB 60/75	90	454	400	182	132	75	168	110	113	28	154	38,5	-	CM-60/75

Series **HBRC** **Hot Bolt & Industrial Clamp**



Replacement of damaged nuts – Industrial Clamping

- FPT is a producer of Hot Bolt and Industrial Clamping System with applications throughout the industrial sectors, oil & gas as well.
- The system has been designed to remove rusted nuts on pipelines where is essential to replace the corroded or damaged nuts without interrupting production.
- The standard system consists of 4 FPTs Hot Bolt of 34 kN with of 10 mm stroke and a maximum working pressure of 700 bar, an FPT hand pump model PMSA2, manifold, flex hoses,

couplings and accessories . Every Hot Bolt is superficially treated to obtain an excellent resistance against corrosion
Product code: KIT-4HBRC-35

- The tools can be operated through multiple outputs electric power unit, pneumo-hydraulic pumps and handpumps and the system can be personalized to meet customer's requirements.

CUSTOM TOOLS ON REQUEST





Series
CB

Hydraulic bottle jacks

SERIES WITH LOAD-BEARING PISTON WITH RISER SCREW

- Complete range of hydraulic bottle jacks
- CB Series with load-bearing piston with riser screw
- Equipped with adjustable extension screws with safety lock and automatic stop valve
- The models are supplied with the suitable lever

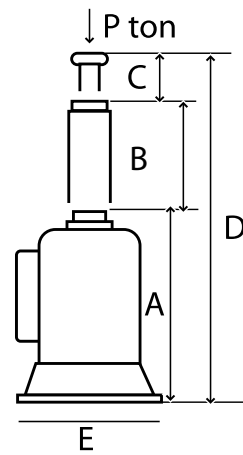

TYPE	TON	A	B	C	D	E	WEIGHT
CB3	3	215	150	-	365	145 x 115	5
CB3/P	3	245	175	-	420	145 x 115	5,5
CB5/P	5	255	180	-	435	145 x 115	7,5
CB3/V with raiser screw	3	215	150	80	445	145 x 115	5
CB5 with raiser screw	5	220	145	85	450	145 x 115	6,5
CB8 with raiser screw	8	250	180	85	515	145 x 115	7,5
CB10 with raiser screw	10	250	170	100	520	170 x 145	11,5
CB15 with raiser screw	15	270	190	100	560	170 x 145	13
CB20 with raiser screw	20	275	190	100	565	195 x 170	15,5
CB25 with raiser screw	25	280	190	100	570	195 x 170	18
CB30 with raiser screw	30	280	190	100	570	200 x 170	20
CB40 with raiser screw	40	280	190	100	570	235 x 210	25
CB50 with raiser screw	50	280	190	100	570	235 x 210	30



Series
CBT

Hydraulic bottle jacks

SERIES WITH TWO TELESCOPIC LOAD-BEARING PISTONS

- Complete range of hydraulic bottle jacks
- CB Series with two load-bearing pistons with riser screws
- Equipped with adjustable extension screws with safety lock and automatic stop valve
- The models are supplied with the suitable lever

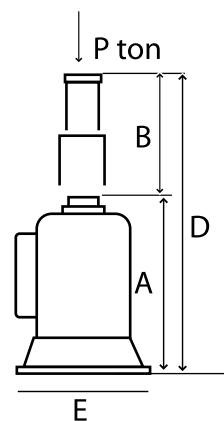

TYPE	TON	LOAD ON 1 ST PISTON	A	B	C	D	E	WEIGHT
CBT1,5	1,5	4	160	200	-	360	145 x 115	5
CBT1,5 with plate	1,5	4	190	200	-	390	145 x 115	5,5
CBT3	3	5	170	210	-	380	145 x 115	6
CBT5	5	10	225	275	-	500	170 x 145	11
CBT10	10	20	230	310	-	540	195 x 170	14
CBT10/BUS	10	20	180	205	-	385	195 x 170	12
CBT15	15	25	230	310	-	540	195 x 170	18
CBT20	20	30	230	310	-	540	195 x 170	20
CBT25	25	40	240	310	-	550	235 x 210	22

Series
PR

Hydraulic Presses

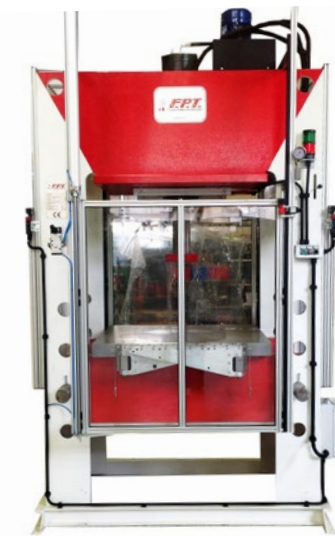

Multipurpose

- Built according to customer needs and specific operative requirements.
- Equipped with safety guards and systems, fixed or mobile bench, push piston and positioning function on request.

- They can also be equipped with a hand pump or hydraulic pump with electric or air motor.
- Correctly sized structure to guarantee maximum strength and stability during operations.

